



FIRE LINE AUTOMATIC 3

BEV Technology® (Burning Ethanol Vapours)

PROTECTIVE GLASS

CONTROL OPTIONS



TOP FINISH

Black powder coating (standard)
Stainless steel (optional)
RAL color (optional)

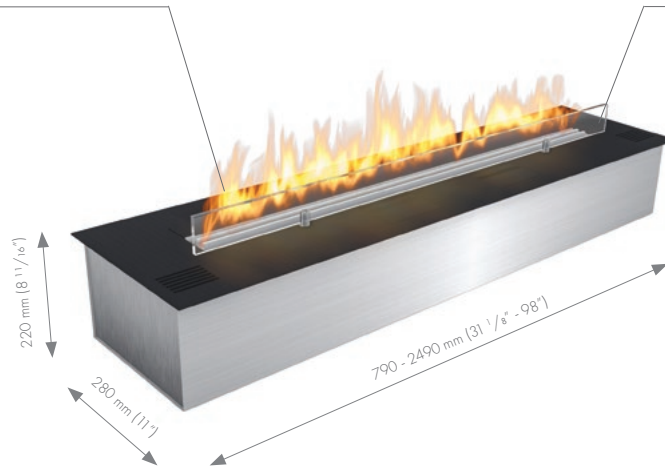

Custom length



6 flame heights



No chimney



Automatic refueling

FIRE LINE AUTOMATIC 3

	790 mm 31 1/8"	990 mm 39"	1190 mm 46 7/8"	1490 mm 58 1/16"	1990 mm 78 3/8"	2490 mm 98"
	2.9 - 6.9 kW 10 009 - 23 426 BTU/h	3.7 - 8.1 kW 12 778 - 27 686 BTU/h	5.0 - 11.2 kW 17 037 - 38 334 BTU/h	6.2 - 15.0 kW 21 297 - 51 113 BTU/h	7.8 - 21.2 kW 26 621 - 72 410 BTU/h	9.4 - 27.5 kW 31 946 - 93 707 BTU/h
	4.5 L [US] 1.19 gal / [UK] 0.99 gal	5.5 L [US] 1.45 gal / [UK] 1.21 gal	8.3 L [US] 1.98 gal / [UK] 1.65 gal	10.0 L [US] 2.64 gal / [UK] 2.20 gal	12.5 L [US] 3.30 gal / [UK] 2.75 gal	15.0 L [US] 3.96 gal / [UK] 3.30 gal
	4.0 - 10.0 h					
	min. 69 m³ / 2437 ft³	min. 81 m³ / 2966 ft³	min. 113 m³ / 3991 ft³	min. 150 m³ / 5297 ft³	min. 212 m³ / 7487 ft³	min. 275 m³ / 9712 ft³
	25 kg / 55 lbs	29.5 kg / 65 lbs	33.5 kg / 74 lbs	40 kg / 88 lbs	51 kg / 112 lbs	61 kg / 134 lbs
	230 V / [US] 115 V					

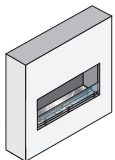

FRONT

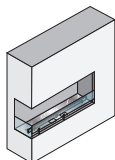

LEFT FRONT / RIGHT FRONT

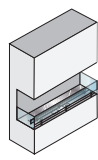

LEFT FRONT RIGHT

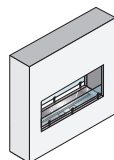

TUNNEL

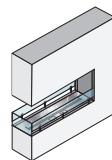

ROOM DIVIDER

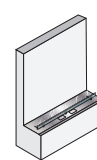

BY WALL



ISLAND

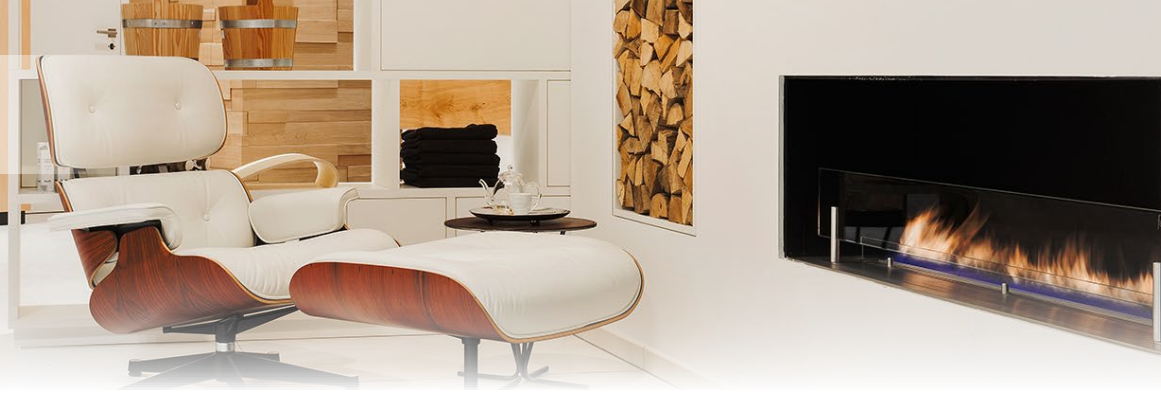

FLA 3 IN CASING A

BEV Technology® (Burning Ethanol Vapours)

PROTECTIVE GLASS

Optional mesh

CONTROL OPTIONS



TOP FINISH

Black powder coating (standard)
Stainless steel (optional)
RAL color (optional)



Custom length



6 flame heights



No chimney



Automatic refueling

FIRE LINE AUTOMATIC 3 IN CASING A

	874 mm 34 7/16"	1074 mm 42 1/4"	1274 mm 50 3/16"	1574 mm 62"	2074 mm 81 5/8"	2574 mm 101 5/16"
	2.9 - 6.9 kW 10 009 - 23 426 BTU/h	3.7 - 8.1 kW 12 778 - 27 686 BTU/h	5.0 - 11.2 kW 17 037 - 38 334 BTU/h	6.2 - 15.0 kW 21 297 - 51 113 BTU/h	7.8 - 21.2 kW 26 621 - 72 410 BTU/h	9.4 - 27.5 kW 31 946 - 93 707 BTU/h
	4.5 L [US] 1.19 gal / [UK] 0.99 gal	5.5 L [US] 1.45 gal / [UK] 1.21 gal	8.3 L [US] 1.98 gal / [UK] 1.65 gal	10.0 L [US] 2.64 gal / [UK] 2.20 gal	12.5 L [US] 3.30 gal / [UK] 2.75 gal	15.0 L [US] 3.96 gal / [UK] 3.30 gal
	4.0 - 10.0 h					
	min. 69 m ³ / 2437 ft ³	min. 81 m ³ / 2966 ft ³	min. 113 m ³ / 3991 ft ³	min. 150 m ³ / 5297 ft ³	min. 212 m ³ / 7487 ft ³	min. 275 m ³ / 9712 ft ³
	230 V / [US] 115 V					

FLA 3 IN CASING ONE

BEV Technology® (Burning Ethanol Vapours)

PROTECTIVE GLASS

CONTROL OPTIONS



TOP FINISH

Black powder coating (standard)
Stainless steel (optional)
RAL color (optional)



Custom length



6 flame heights



No chimney



Automatic refueling

FIRE LINE AUTOMATIC 3 IN CASING ONE

	1080 mm 42 1/2"	1280 mm 50 3/8"	1480 mm 58 1/4"	1680 mm 66 1/8"	2280 mm 89 3/4"
	2.9 - 6.9 kW 10 009 - 23 426 BTU/h	3.7 - 8.1 kW 12 778 - 27 686 BTU/h	5.0 - 11.2 kW 17 037 - 38 334 BTU/h	6.2 - 15.0 kW 21 297 - 51 113 BTU/h	7.8 - 21.2 kW 26 621 - 72 410 BTU/h
	4.5 L [US] 1.19 gal / [UK] 0.99 gal	5.5 L [US] 1.45 gal / [UK] 1.21 gal	8.3 L [US] 1.98 gal / [UK] 1.65 gal	10.0 L [US] 2.64 gal / [UK] 2.20 gal	12.5 L [US] 3.30 gal / [UK] 2.75 gal
	4.0 - 10.0 h				
	min. 69 m³ / 2437 ft³	min. 81 m³ / 2966 ft³	min. 113 m³ / 3991 ft³	min. 150 m³ / 5297 ft³	min. 212 m³ / 7487 ft³
	230 V / [US] 115 V				



FRONT



LEFT FRONT / RIGHT FRONT



LEFT FRONT RIGHT



TUNNEL



ROOM DIVIDER LEFT / RIGHT



ISLAND

CASING ONE (FLA 3)

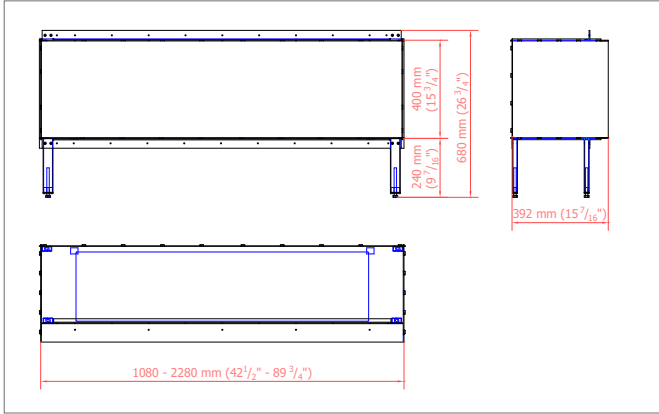

CASING ONE FRONT

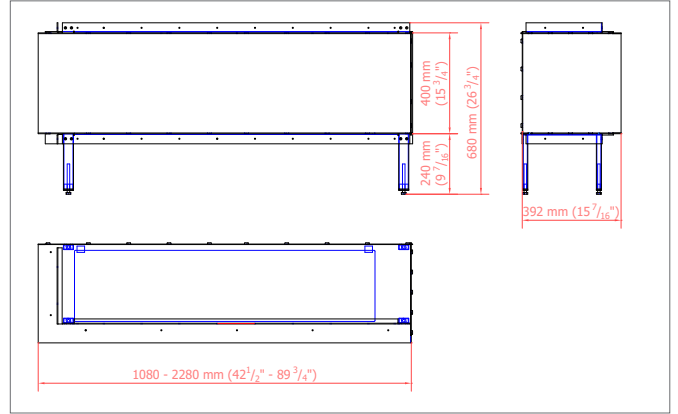

CASING ONE LEFT-FRONT / FRONT-RIGHT

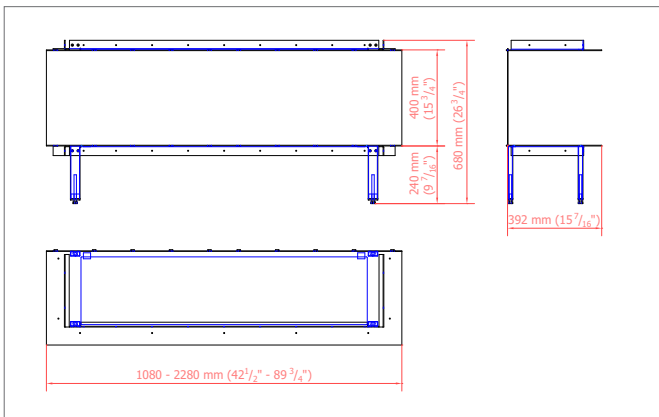

CASING ONE LEFT-FRONT-RIGHT

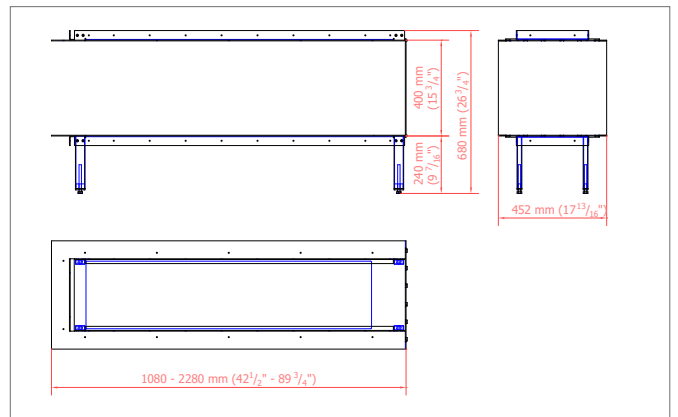

CASING ONE ROOM DIVIDER LEFT / RIGHT

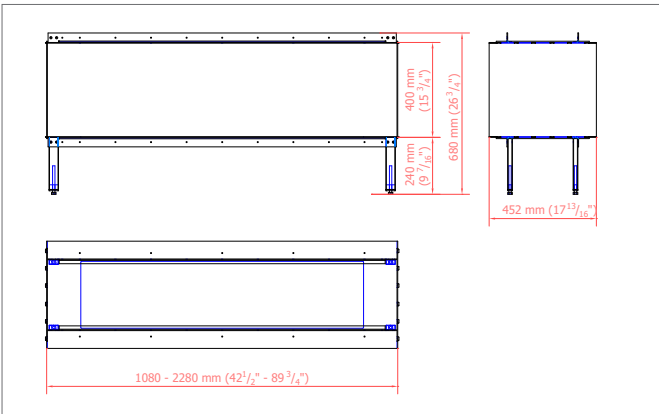

CASING ONE TUNNEL

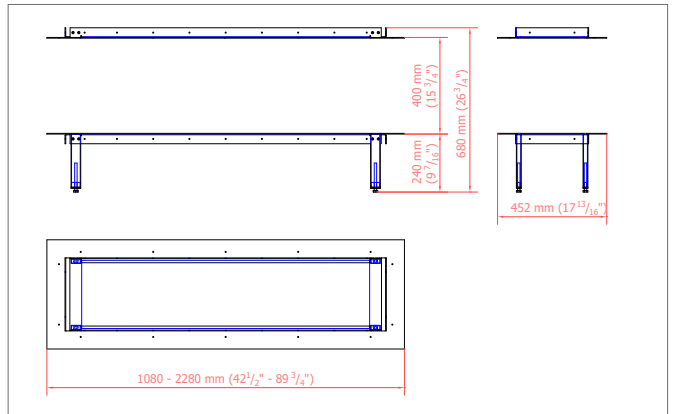

CASING ONE ISLAND



FIRE LINE AUTOMATIC 3 XL

BEV Technology® (Burning Ethanol Vapours)

PROTECTIVE GLASS

CONTROL OPTIONS



TOP FINISH

Black powder coating (standard)
Stainless steel (optional)
RAL color (optional)

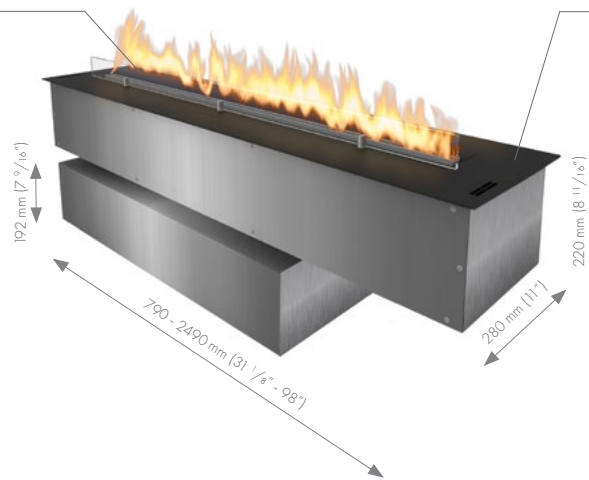

Custom length



6 flame heights



No chimney



Automatic refueling

FIRE LINE AUTOMATIC 3 XL

	790 mm 31 1/8"	990 mm 39"	1190 mm 46 7/8"	1490 mm 58 11/16"	1990 mm 78 3/8"	2490 mm 98"
	2.9 - 6.9 kW 10 009 - 23 426 BTU/h	3.7 - 8.1 kW 12 778 - 27 686 BTU/h	5.0 - 11.2 kW 17 037 - 38 334 BTU/h	6.2 - 15.0 kW 21 297 - 51 113 BTU/h	7.8 - 21.2 kW 26 621 - 72 410 BTU/h	9.4 - 27.5 kW 31 946 - 93 707 BTU/h
	24.0 L [US] 6.34 gal / [UK] 5.28 gal					
	20.0 - 44.0 h	18.5 - 40.0 h	13.0 - 30.0 h	10.0 - 24.0 h	7.0 - 19.0 h	5.5 - 16.0 h
	min. 69 m³ / 2440 ft³	min. 81 m³ / 2860 ft³	min. 113 m³ / 3990 ft³	min. 150 m³ / 5300 ft³	min. 212 m³ / 7490 ft³	min. 275 m³ / 9710 ft³
	32.1 kg / 70.8 lbs	35.1 kg / 77.4 lbs	38.1 kg / 84.0 lbs	42.6 kg / 94.0 lbs	50.3 kg / 110.9 lbs	57.8 kg / 127.4 lbs
	230 V / [US] 115 V					

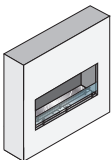

FRONT

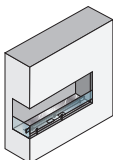

LEFT FRONT / RIGHT FRONT

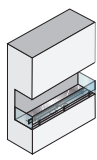

LEFT FRONT RIGHT

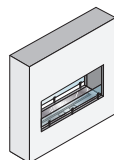

TUNNEL

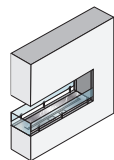

ROOM DIVIDER

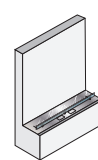

BY WALL



ISLAND

FLA 3 XL IN CASING A

BEV Technology® (Burning Ethanol Vapours)

PROTECTIVE GLASS

Optional mesh

CONTROL OPTIONS



TOP FINISH

Black powder coating (standard)
Stainless steel (optional)
RAL color (optional)

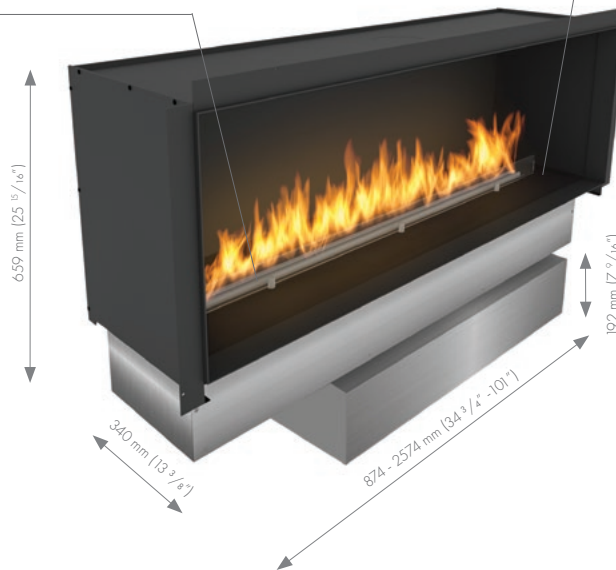

Custom length



6 flame heights



No chimney



Automatic refueling

FIRE LINE AUTOMATIC 3 XL IN CASING A

	874 mm 31 1/8"	1074 mm 42 1/4"	1274 mm 50 1/8"	1574 mm 62"	2074 mm 81 5/8"	2574 mm 101 5/16"
	2.9 - 6.9 kW 10 009 - 23 426 BTU/h	3.7 - 8.1 kW 12 778 - 27 686 BTU/h	5.0 - 11.2 kW 17 037 - 38 334 BTU/h	6.2 - 15.0 kW 21 297 - 51 113 BTU/h	7.8 - 21.2 kW 26 621 - 72 410 BTU/h	9.4 - 27.5 kW 31 946 - 93 707 BTU/h
	24.0 L [US] 6.34 gal / [UK] 5.28 gal					
	20.0 - 44.0 h	18.5 - 40.0 h	13.0 - 30.0 h	10.0 - 24.0 h	7.0 - 19.0 h	5.5 - 16.0 h
	min. 69 m ³ / 2440 ft ³	min. 81 m ³ / 2860 ft ³	min. 113 m ³ / 3990 ft ³	min. 150 m ³ / 5300 ft ³	min. 212 m ³ / 7490 ft ³	min. 275 m ³ / 9710 ft ³
	230 V / [US] 115 V					

FLA 3 XL IN CASING ONE

BEV Technology® (Burning Ethanol Vapours)

PROTECTIVE GLASS

CONTROL OPTIONS



TOP FINISH

Black powder coating (standard)
Stainless steel (optional)
RAL color (optional)



Custom length



6 flame heights



No chimney



Automatic refueling

FIRE LINE AUTOMATIC 3 XL IN CASING ONE

	1080 mm 42 1/2"	1280 mm 50 3/8"	1480 mm 58 1/4"	1680 mm 66 1/8"	2280 mm 89 3/4"
	2.9 - 6.9 kW 10 009 - 23 426 BTU/h	3.7 - 8.1 kW 12 778 - 27 686 BTU/h	5.0 - 11.2 kW 17 037 - 38 334 BTU/h	6.2 - 15.0 kW 21 297 - 51 113 BTU/h	7.8 - 21.2 kW 26 621 - 72 410 BTU/h
	24.0 L [US] 6.34 gal / [UK] 5.28 gal				
	20.0 - 44.0 h	18.5 - 40.0 h	13.0 - 30.0 h	10.0 - 24.0 h	7.0 - 19.0 h
	min. 69 m ³ / 2440 ft ³	min. 81 m ³ / 2860 ft ³	min. 113 m ³ / 3990 ft ³	min. 150 m ³ / 5300 ft ³	min. 212 m ³ / 7490 ft ³
	230 V / [US] 115 V				



FRONT



LEFT FRONT / RIGHT FRONT



LEFT FRONT RIGHT



TUNNEL



ROOM DIVIDER LEFT / RIGHT



ISLAND

CASING ONE (FLA 3 XL)

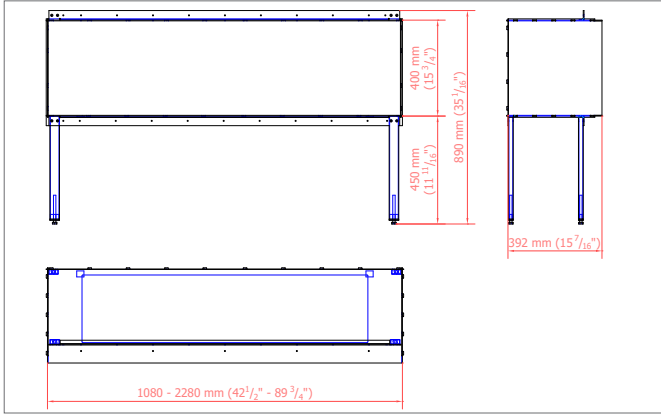

CASING ONE FRONT

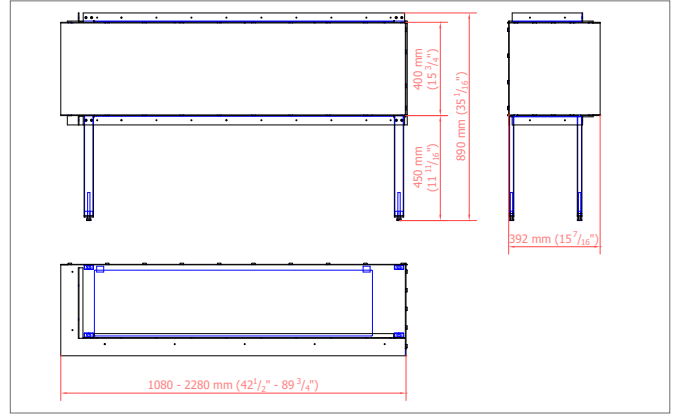

CASING ONE LEFT-FRONT / FRONT-RIGHT

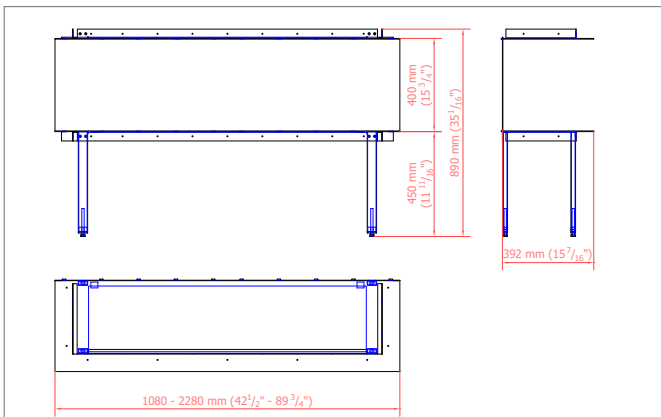

CASING ONE LEFT-FRONT-RIGHT

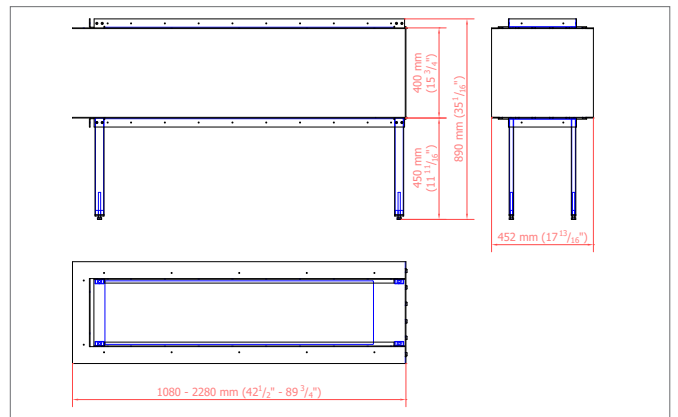

CASING ONE ROOM DIVIDER LEFT / RIGHT

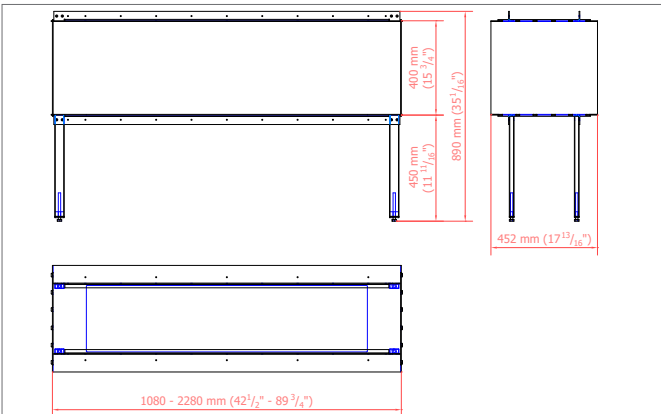

CASING ONE TUNNEL

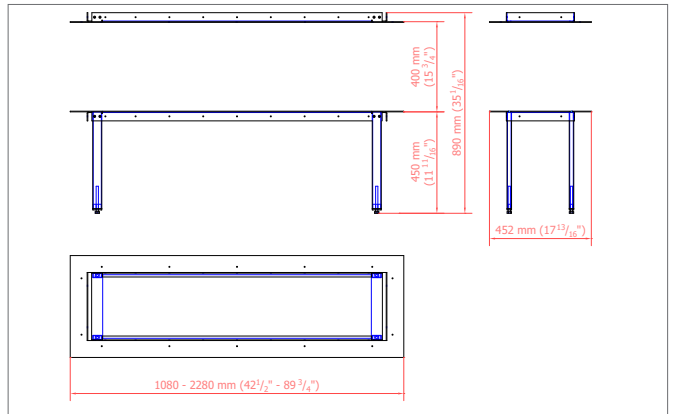

CASING ONE ISLAND



FLA 3 XL SUITE LOGS

BEV Technology® (Burning Ethanol Vapours)



PROTECTIVE GLASS

CONTROL OPTIONS



Custom length



6 flame heights



No chimney



Automatic refueling

FIRE LINE AUTOMATIC 3 SUITE LOGS

	5.0 - 9.4 kW / 17 038 - 31 946 BTU/h
	24.0 L / [US] 6.34 gal / [UK] 5.28 gal
	16 - 30 h
	min. 94 m ³ / 3320 ft ³
	89.0 kg / 196.2 lbs
	230 V / [US] 115 V



FRONT



LEFT FRONT / RIGHT FRONT



LEFT FRONT RIGHT



PRIME FIRE

BEV Technology® (Burning Ethanol Vapours)

PROTECTIVE GLASS

TOP FINISH

Black powder coating

OPTIONAL CONTROL

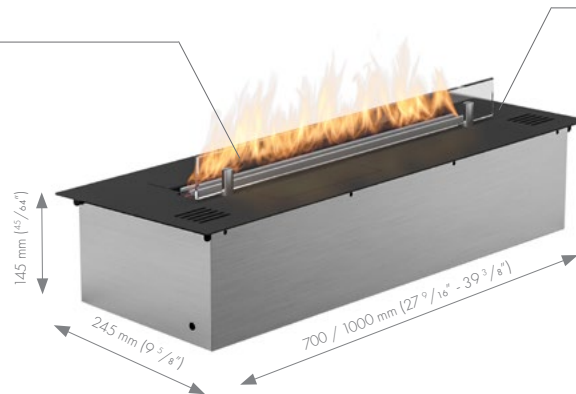

2 flame heights



No chimney



Automatic refueling

PRIME FIRE

	700 mm 27 5/8"	1000 mm 39 3/8"
	1.9 - 3.1 kW / 6 839 - 10 648 BTU/h	3.7 - 5.6 kW / 12 778 - 19 167 BTU/h
	2.0 L / [US] 0.5 gal / [UK] 0.4 gal	3.5 L / [US] 0.9 gal / [UK] 0.8 gal
	4.0 - 6.5 h	4.0 - 6.0 h
	min. 31 m ³ / 1095 ft ³	min. 56 m ³ / 1978 ft ³
	12.0 kg / 26.5 lbs	approx. 18.2 kg / 40.1 lbs
	230 V / [US] 115 V	

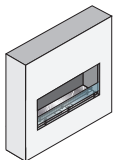

FRONT

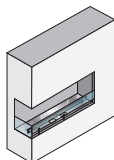

LEFT FRONT / RIGHT FRONT

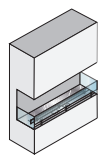

LEFT FRONT RIGHT

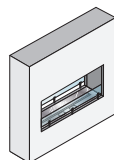

TUNNEL

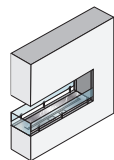

ROOM DIVIDER

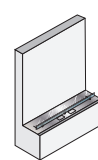

BY WALL



ISLAND



PRIME FIRE IN CASING

BEV Technology® (Burning Ethanol Vapours)



PROTECTIVE GLASS

Optional mesh

OPTIONAL CONTROL



2 flame heights



No chimney



Automatic refueling

PRIME FIRE IN CASING

	784 mm 30 ⁷ / ₈ "	1084 mm 42 ¹¹ / ₁₆ "
	1.9 - 3.1 kW / 6 839 - 10 648 BTU/h	3.7 - 5.6 kW / 12 778 - 19 167 BTU/h
	2.0 L / [US] 0.5 gal / [UK] 0.4 gal	3.5 L / [US] 0.9 gal / [UK] 0.8 gal
	4.0 - 6.5 h	4.0 - 6.0 h
	min. 31 m ³ / 1090 ft ³	min. 56 m ³ / 1978 ft ³
	18.0 kg / 40.0 lbs	26.0 kg / 57.3 lbs
	230 V / [US] 115 V	



BASKET FIRE LOGS

BEV Technology® (Burning Ethanol Vapours)

PROTECTIVE GLASS

TOP FINISH

Black powder coating

CONTROL OPTIONS



OPTIONAL



Freestanding



2 flame heights



No chimney



Automatic refueling

BASKET FIRE LOGS

	550 mm 21 5/8"
	2.5 kW 8 520 BTU/h
	1.8 L [US] 0.48 gal / [UK] 0.4 gal
	max. 4.5 h
	min. 25 m ³ / 880 ft ³
	14.8 kg / 32.6 lbs
	230 V / [US] 115 V



L-FIRE

BEV Technology® (Burning Ethanol Vapours)

OPTIONAL CONTROL



TOP FINISH

Black powder coating

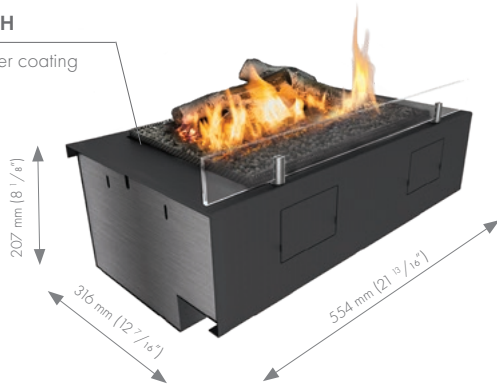

2 flame heights



No chimney



Automatic refueling

	L-FIRE	L-FIRE IN CASING
	2.5 - 4.4 kW / 8 515 - 14 908 BTU/h	
	6.0 L / [US] 1.58 gal / [UK] 1.32 gal	
	8.5 - 15 h	
	min. 44 m ³ / 1554 ft ³	
	16.5 kg / 36.4 lbs	27.0 kg / 59.5 lbs
	230 V / [US] 115 V	



LINCOLN

BEV Technology® (Burning Ethanol Vapours)

PROTECTIVE GLASS

Optional mesh

FINISH

White MDF

CONTROL OPTIONS



TOP FINISH

Black powder coating



Freestanding



2 flame heights



No chimney



Easy refueling system

LINCOLN

	2.5 - 4.4 kW 8 515 - 14 908 BTU/h
	6.0 L [US] 1.58 gal / [UK] 1.32 gal
	8.5 - 15 h
	min. 44 m ³ / 1550 ft ³
	57.0 kg / 126.0 lbs
	230 V / [US] 115 V



PURE FLAME

BEV Technology® (Burning Ethanol Vapours)

PROTECTIVE GLASS

Optional mesh

CONTROL OPTIONS



OPTIONAL

TOP FINISH

Black powder coating



Insert for installation in furniture



2 flame heights



No chimney



Easy refueling system

PURE FLAME

	5 kW 17 038 BTU/h
	5.0L [US] 1.32 gal / [UK] 1.01 gal
	6.25 - 12.5 h
	min. 50 m ³ / 1770 ft ³
	22.5 kg / 49.6 lbs
	230 V / [US] 115 V



PURE FLAME TV BOX

BEV Technology® (Burning Ethanol Vapours)

PROTECTIVE GLASS

Optional mesh

CONTROL OPTIONS



OPTIONAL

TOP FINISH

White MDF
Natural oak veneer



Freestanding



2 flame heights



No chimney



Easy refueling system

PURE FLAME TV BOX

	1860 mm 73 2/8"
	5 kW 17 038 BTU/h
	5.0 L [US] 1.32 gal / [UK] 1.01 gal
	6.25 - 12.5 h
	min. 50 m ³ / 1770 ft ³
	76.0 kg / 168.0 lbs
	230 V / [US] 115 V

ETHANOL OUTDOOR FIRES

Commerce Technology™ (Absorbent Ceramic Fibers)



No smoke or ash



No electricity required



Safe burning technology



Easy refueling system

	CARO	TOTEM	GUSTAV	JAR	TONDO
	[ØxH] 383 x 1189 mm [ØxH] 15 1/16" x 46 13/16"	[ØxH] 395 x 1070 mm [ØxH] 15 1/2" x 42 1/4"	[ØxH] 444 x 962 mm [ØxH] 17 1/2" x 37 7/8"	[ØxH] 410 x 795 mm [ØxH] 16 1/8" x 31 5/16"	[ØxH] 700 x 423 mm [ØxH] 27 9/16" x 16 5/8"
	10.3 kg / 22.7 lbs	24.5 kg / 54.0 lbs	16.3 kg / 35.8 lbs	41.5 kg / 91.5 lbs	14.0 kg / 30.9 lbs
	2.5 kW / 8 547 BTU/h				
	3.0 L / [US] 0.78 gal / [UK] 0.66 gal				
	6.5 h				
	min. 25 m³ / 882 ft³				

FIRE TABLES

Commerce Technology™ (Absorbent Ceramic Fibers)



CARO TABLE



TONDO TABLE



JAR TABLE



No smoke or ash





No electricity required



Safe burning technology



Easy refueling system

	CARO TABLE	TONDO TABLE	JAR TABLE
	[ØxH] 680 x 1189 mm [ØxH] 26 3/4" x 46 13/16"	[ØxH] 800 x 683 mm [ØxH] 31 1/2" x 26 7/8"	[ØxH] 680 x 772 mm [ØxH] 26 3/4" x 30 3/8"
	10.3 kg / 22.7 lbs	24.1 kg / 53.1 lbs	49.0 kg / 108.0 lbs
	2.5 kW / 8 519 BTU/h		
	3.0 L / [US] 0.78 gal / [UK] 0.66 gal		
	6.5 h		
	min. 25 m³ / 880 ft³		

FIRE TABLES

Commerce Technology™ (Absorbent Ceramic Fibers)



FIRE COFFEE TABLE



FIRE TABLE MINI



FIRE TABLE ROUND



No smoke or ash









No electricity required



Safe burning technology



Easy refueling system

	FIRE COFFEE TABLE	FIRE TABLE MINI	FIRE TABLE ROUND
	[LxHxD] 1180 x 700 x 420 mm [LxHxD] 46 7/16" x 27 9/16" x 16 9/16"	[LxHxD] 900 x 600 x 420 mm [LxHxD] 35 7/16" x 23 5/8" x 16 9/16"	[ØxH] 615 x 400 mm [ØxH] 24 3/16" x 15 3/4"
	36.0 kg / 79.4 lbs	15.8 kg / 34.8 lbs	7.0 kg / 15.4 lbs
	Varnished natural OSB / Black varnished OSB White MDF / Black MDF	Varnished natural OSB / White MDF	Varnished natural OSB / Black varnished OSB
	2.5 kW / 8 519 BTU/h		
	1.5 L / [US] 0.4 gal / [UK] 0.33 gal		
	3.5 h		
	min. 25 m ³ / 880 ft ³		

ETHANOL TABLETOP FIRES

Commerce Technology™ (Absorbent Ceramic Fibers)



SIMPLE

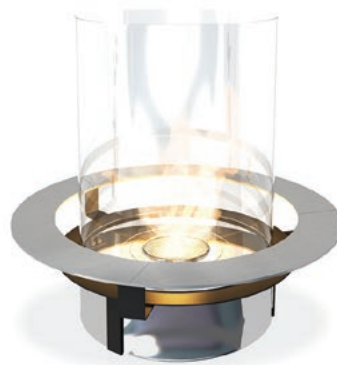

RONDO



DANCING FLAME



No smoke or ash



No electricity required



Safe burning technology



Easy refueling system

	SIMPLE	RONDO	DANCING FLAME
	[ØxH] 308 x 418 mm [ØxH] 12 1/8" x 16 7/16"	[ØxH] 412 x 412 mm [ØxH] 16 1/4" x 16 1/4"	[ØxH] 444 x 962 mm [ØxH] 17 1/2" x 37 7/8"
	6.5 kg / 14.3 lbs	7.0kg / 15.4 lbs	2.0kg / 4.4 lbs
	1.5 L / [US] 0.4 gal / [UK] 0.33 gal	3.0 L / [US] 0.8 gal / [UK] 0.66 gal	1.5 L / [US] 0.4 gal / [UK] 0.33 gal
	3.5 h	6.5 h	3.5 h
	2.5 kW / 8 519 BTU/h		
	min. 25 m ³ / 880 ft ³		



VALENTINO

Linear fire (balanced flue system)



BACK WALL FINISH

Black matte steel (standard)
Black ceramic glass (optional)

DECORATION

Logs, granules & chips
Black diamond stones
Pebbles & gold vermiculite

CONTROL OPTIONS



STANDARD OPTIONAL COMPATIBLE



Thermostat



Modular burner



Gas and CO detectors



Antireflective glass

VALENTINO

	1000 mm 39 3/8"	1300 mm 51 3/16"
	(NG) max. 6.4 kW 21 837 BTU/h (LPG) max. 6.7 kW 22 861 BTU/h	(NG) max. 8.5 kW 29 003 BTU/h (LPG) max. 7.4 kW 25 250 BTU/h
	(NG) max. 0.9 m ³ /h 31.8 ft ³ /h (LPG) max. 0.7 kg/h 1.54 lbs/h	(NG) max. 1.2 m ³ /h 42.4 ft ³ /h (LPG) max. 0.78 kg/h 1.72 lbs/h
	Concentric flue 200/130	
	230 V / [US] 115 V	



FRONT



LEFT FRONT



RIGHT FRONT



LEFT FRONT RIGHT

VALENTINO FRONT

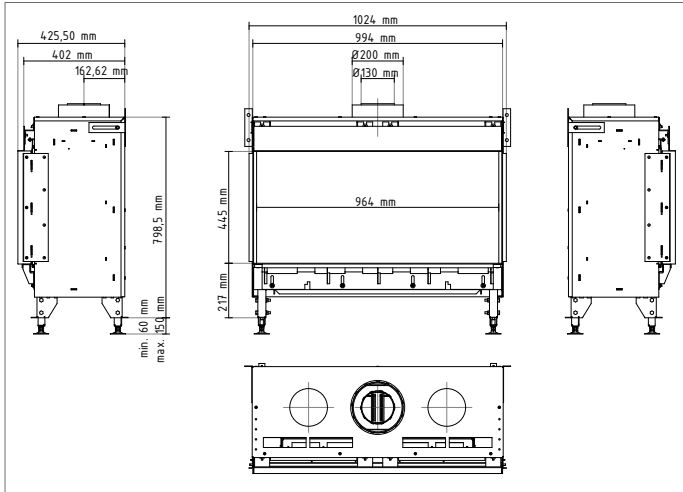

VALENTINO 1000

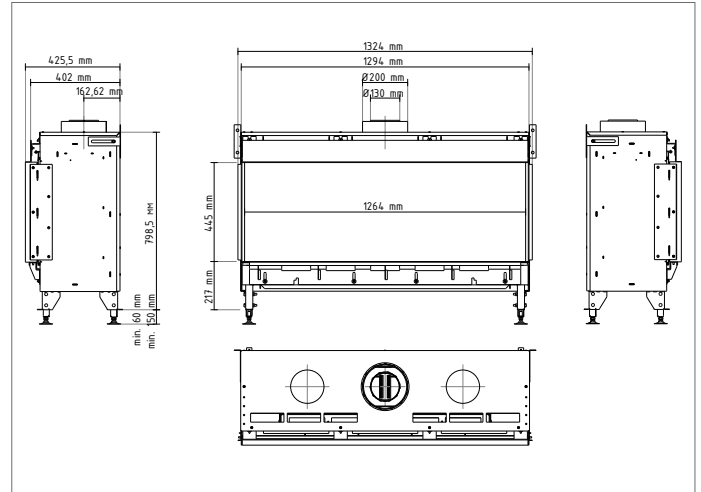

VALENTINO 1300

VALENTINO LEFT FRONT / RIGHT FRONT

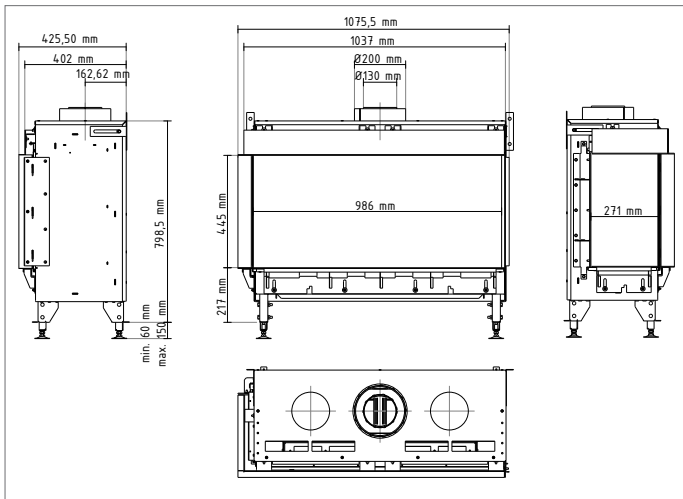

VALENTINO 1000

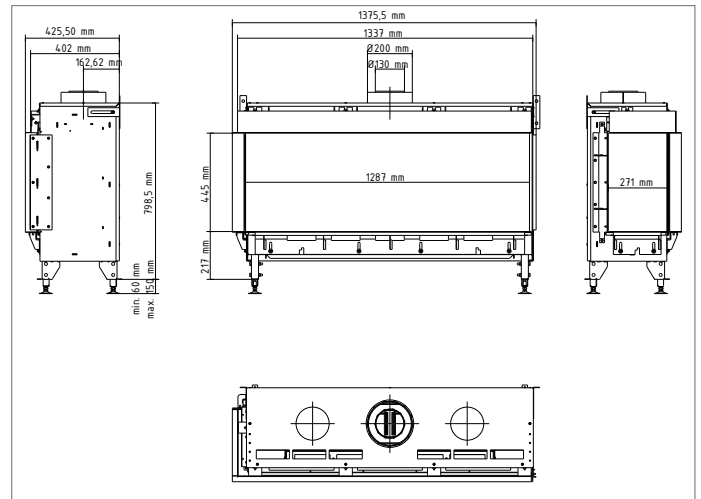

VALENTINO 1300

VALENTINO LEFT FRONT RIGHT

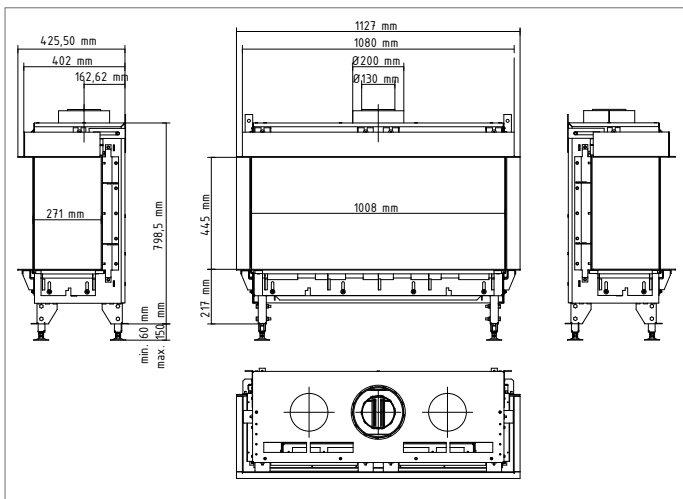

VALENTINO 1000

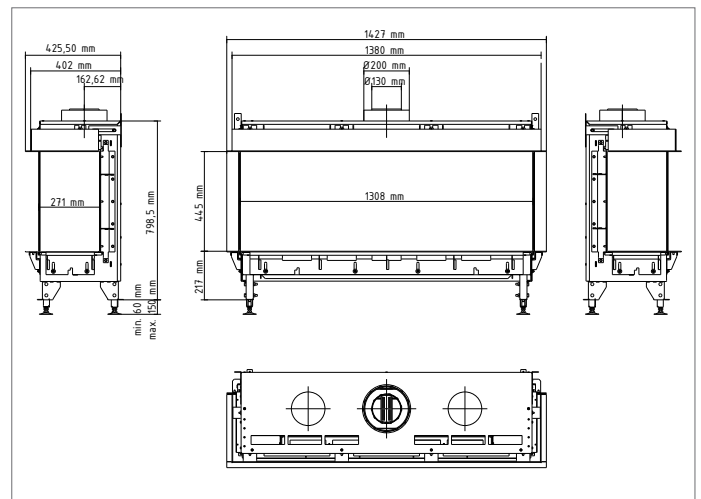

VALENTINO 1300



MONROE

Campfire burner (balanced flue system)



BACK WALL FINISH

Black matte steel (standard)
Black ceramic glass (optional)
Brick panel (optional)

CONTROL OPTIONS



Thermostat



Modular burner



Gas and CO detectors



Antireflective glass

MONROE

900 mm | 35 7/16"

(NG) max. 8.3 kW | 28 320 BTU/h
(LPG) max. 9.2 kW | 31 392 BTU/h

(NG) max. 1.2 m³/h | 42.4 ft³/h
(LPG) max. 0.96 kg/h | 2.12 lbs/h

Concentric flue

230 V / [US] 115 V



FRONT



LEFT FRONT



RIGHT FRONT



LEFT FRONT RIGHT

MONROE FRONT

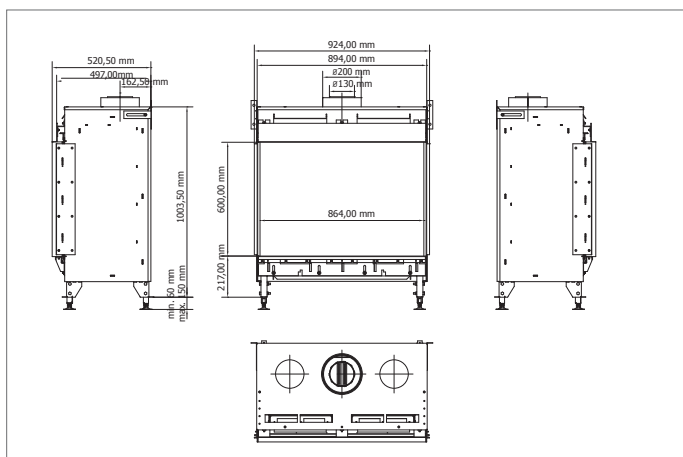

MONREO LEFT FRONT / RIGHT FRONT

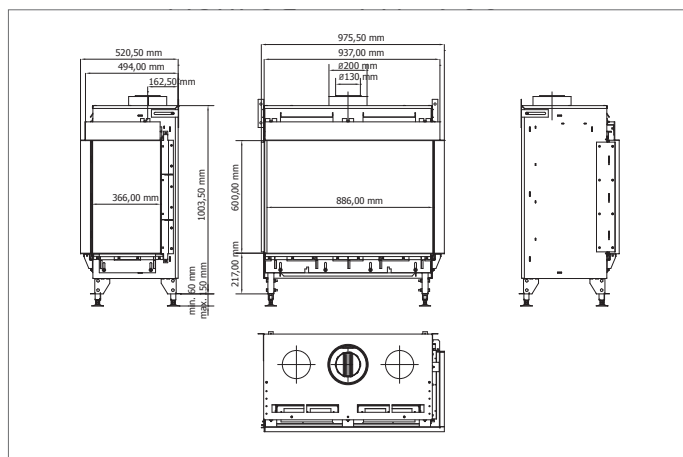
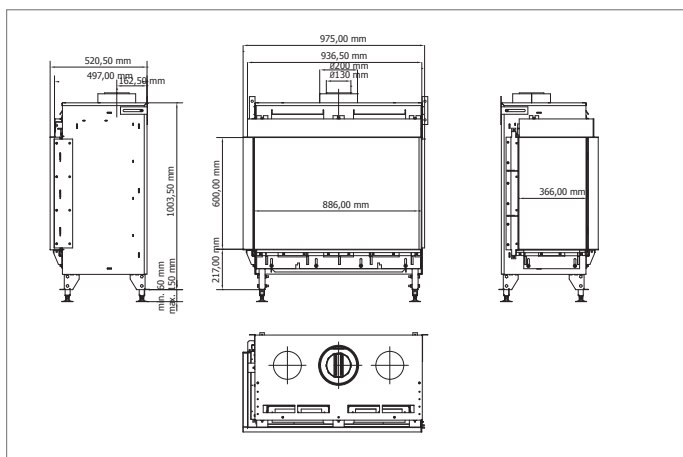

MONREO LEFT FRONT RIGHT

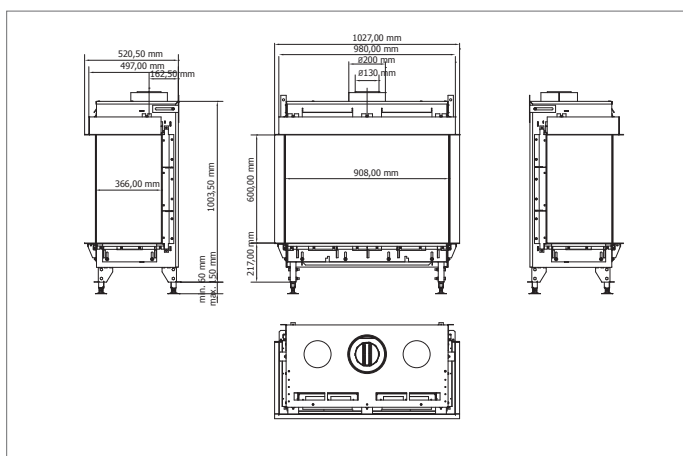



SINATRA

Linear Fire (conventional flue system)



BACK WALL FINISH

- Black matte steel
- Black ceramic glass
- Brick panel

DECORATION

- Logs, granules & chips
- Black diamond stones
- Pebbles & gold vermiculite
- Glass embers
- LED + Crystal diamond embers

CONTROL OPTIONS

 STANDARD
  OPTIONAL
  COMPATIBLE



Custom length







Gas and CO detectors



Ceramic or antireflective glass (or no glass)

SINATRA

	1200 mm 47' 1/4"	1600 mm 63"	2000 mm 78' 3/4"	2400 mm 94' 1/2"
	(NG) max. 10.3 kW 35 145 BTU/h (LPG) max. 9.5 kW 32 415 BTU/h	(NG) max. 15.0 kW 51 185 BTU/h (LPG) max. 14.3 kW 48 794 BTU/h	(NG) max. 19.7 kW 67 219 BTU/h (LPG) max. 19.0 kW 64 831 BTU/h	(NG) max. 19.8 kW 67 560 BTU/h (LPG) max. 20.0 kW 68 243 BTU/h
	(NG) max. 1.09 m ³ /h 38.5 ft ³ /h (LPG) max. 0.75 kg/h 1.65 lbs/h	(NG) max. 1.58 m ³ /h 55.8 ft ³ /h (LPG) max. 1.12 kg/h 2.47 lbs/h	(NG) max. 2.09 m ³ /h 73.8 ft ³ /h (LPG) max. 1.50 kg/h 3.31 lbs/h	(NG) max. 2.09 m ³ /h 73.8 ft ³ /h (LPG) max. 1.57 kg/h 3.46 lbs/h
	Conventional			
	230 V / [US] 115 V			



FRONT



LEFT FRONT



RIGHT FRONT



LEFT FRONT RIGHT



TUNNEL



ROOM DIVIDER



ISLAND

SINATRA FRONT

Sinatra - F 1200

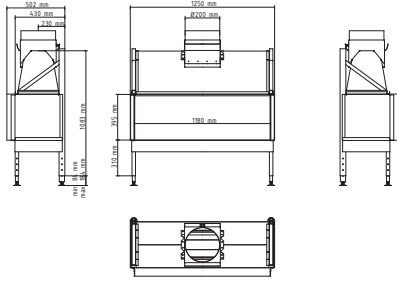

Sinatra - F 1600

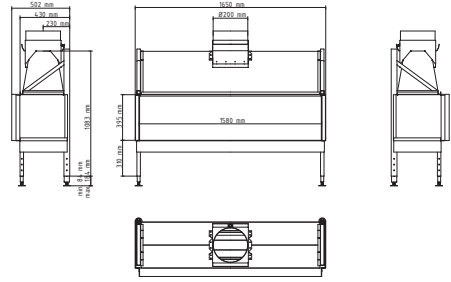

Sinatra - F 2000

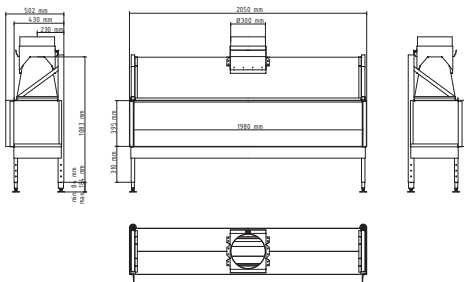

Sinatra - F 2400

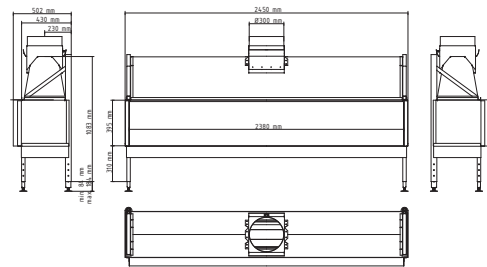

SINATRA LEFT FRONT / RIGHT FRONT

Sinatra - LF 1200

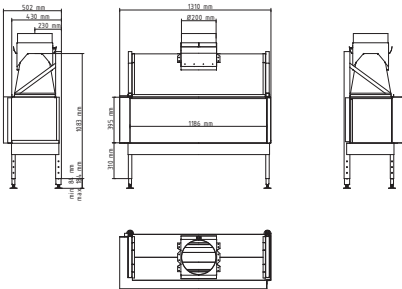

Sinatra - LF 1600

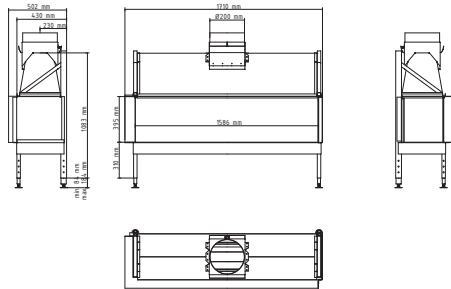

Sinatra - LF 2000

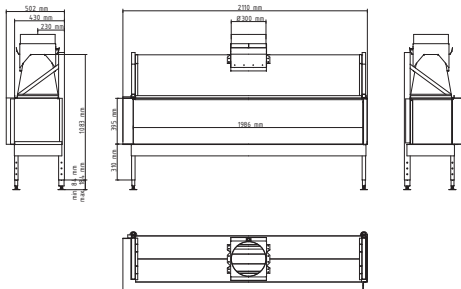

Sinatra - LF 2400

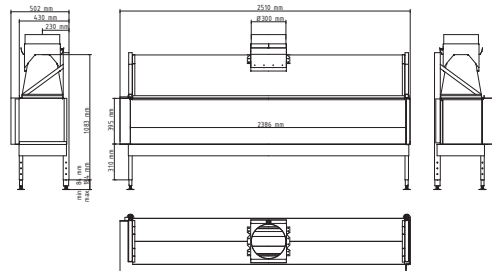

SINATRA LEFT FRONT RIGHT

Sinatra - LFR 1200

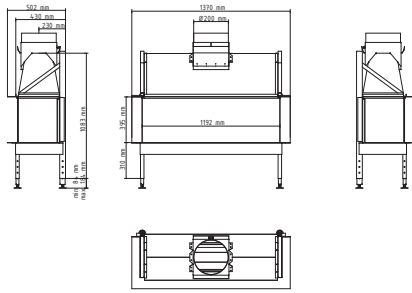

Sinatra - LFR 1600

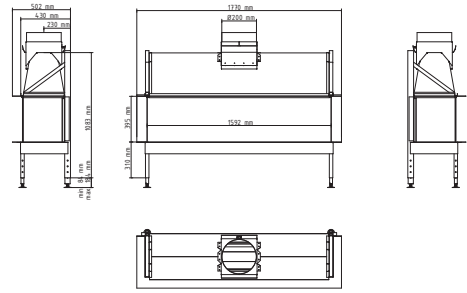

Sinatra - LFR 2000

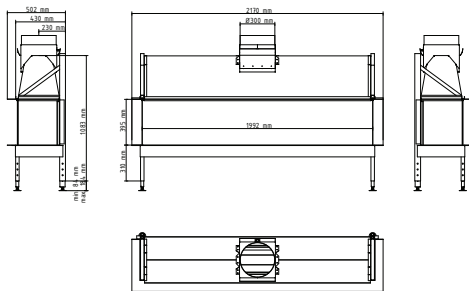

Sinatra - LFR 2400

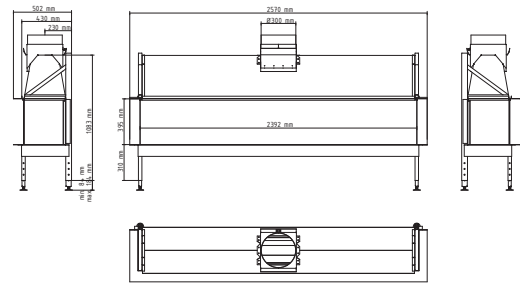

SINATRA TUNNEL

Sinatra - Tunnel 1200

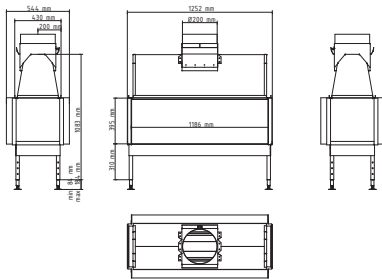

Sinatra - Tunnel 1600

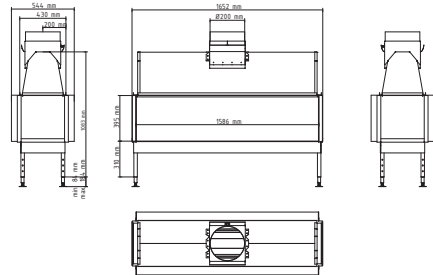

Sinatra - Tunnel 2000

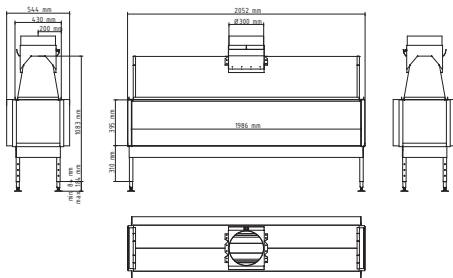

Sinatra - Tunnel 2400

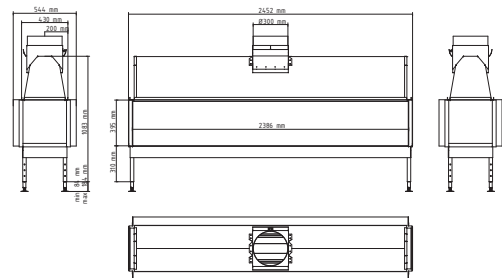

SINATRA ROOM DIVIDER

Sinatra - Room Divider 1200

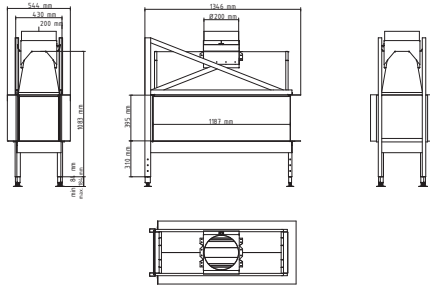

Sinatra - Room Divider 1600

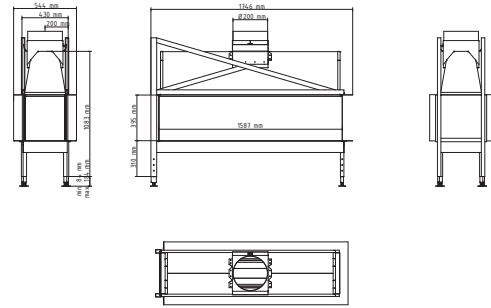

Sinatra - Room Divider 2000

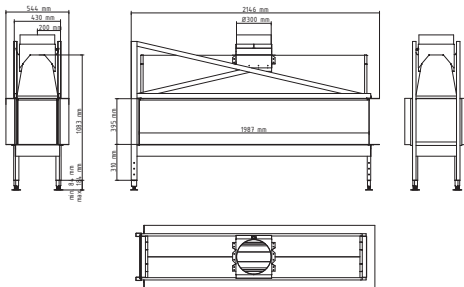

Sinatra - Room Divider 2400

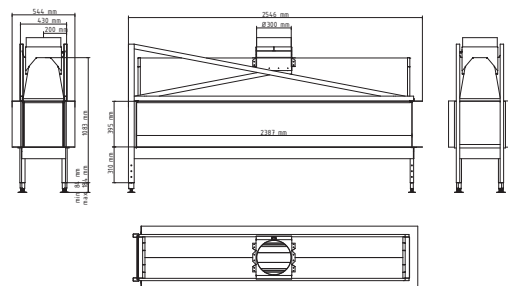

SINATRA ISLAND

Sinatra - Island 1200

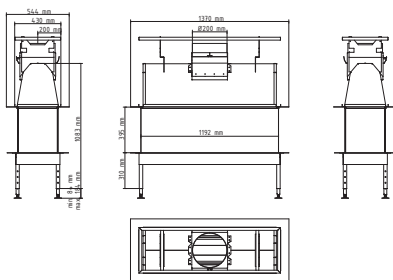

Sinatra - Island 1600

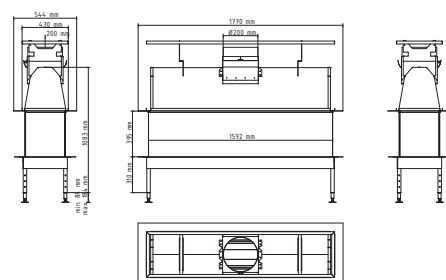

Sinatra - Island 2000

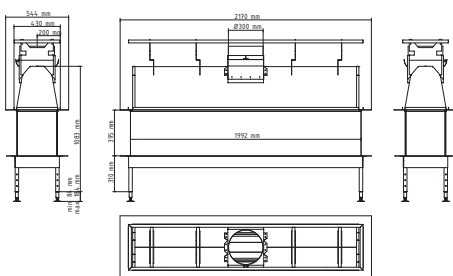

Sinatra - Island 2400

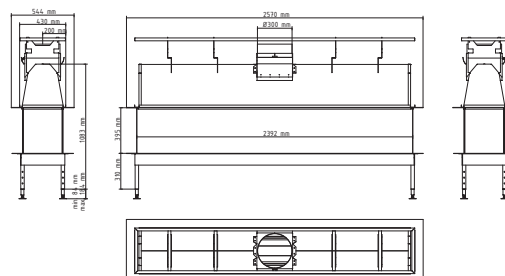



VERSAL INSERT

Linear Fire (conventional flue system)



DECORATION

Logs & chips

CONTROL OPTIONS



Easy to install



Ambient LED illumination

VERSAL INSERT

	350 mm 13 3/4"	550 mm 21 5/8"	700 mm 27 9/16"	850 mm 33 7/16"
	(NG) max. 3.0 kW 10 236 BTU/h (LPG) max. 3.8 kW 12 966 BTU/h	(NG) max. 4.5 kW 15 355 BTU/h (LPG) max. 4.9 kW 16 719 BTU/h	(NG) max. 5.2 kW 17 743 BTU/h (LPG) max. 5.9 kW 20 132 BTU/h	(NG) max. 7.4 kW 25 250 BTU/h (LPG) max. 7.6 kW 25 932 BTU/h
	(NG) max. 0.32 m³/h 11.3 ft³/h (LPG) max. 0.30 kg/h 0.66 lbs/h	(NG) max. 0.48 m³/h 17.0 ft³/h (LPG) max. 0.39 kg/h 0.86 lbs/h	(NG) max. 0.55 m³/h 19.4 ft³/h (LPG) max. 0.47 kg/h 1.03 lbs/h	(NG) max. 0.79 m³/h 27.9 ft³/h (LPG) max. 0.60 kg/h 1.32 lbs/h
	Conventional			
	230 V / [US] 115 V			



VERSAL INSERT (350mm)



VERSAL INSERT (550mm)



VERSAL INSERT (700mm)



VERSAL INSERT (850mm)



VERSAL CASSETTE

Linear Fire (conventional flue system)

DECORATION

Logs & chips

BACK WALL FINISH

Black matte steel (standard)
Black ceramic glass (optional)
Brick panel (optional)

OPTIONAL DECORATIVE FRAME



CONTROL OPTIONS



Easy to install



Ambient LED illumination

VERSAL CASSETTE

	400 mm 15 3/4"	600 mm 23 5/8"	750 mm 29 1/2"	900 mm 35 7/16"
	(NG) max. 3.0 kW 10 236 BTU/h (LPG) max. 3.8 kW 12 966 BTU/h	(NG) max. 4.6 kW 15 696 BTU/h (LPG) max. 4.9 kW 16 719 BTU/h	(NG) max. 5.3 kW 18 084 BTU/h (LPG) max. 6.0 kW 20 473 BTU/h	(NG) max. 7.5 kW 25 591 BTU/h (LPG) max. 7.6 kW 25 932 BTU/h
	(NG) max. 0.32 m ³ /h 11.3 ft ³ /h (LPG) max. 0.30 kg/h 0.66 lbs/h	(NG) max. 0.49 m ³ /h 17.3 ft ³ /h (LPG) max. 0.39 kg/h 0.86 lbs/h	(NG) max. 0.56 m ³ /h 19.8 ft ³ /h (LPG) max. 0.47 kg/h 1.03 lbs/h	(NG) max. 0.79 m ³ /h 27.9 ft ³ /h (LPG) max. 0.60 kg/h 1.32 lbs/h
	Conventional			
	230 V / [US] 115 V			



VERSAL CASSETTE (400mm)



VERSAL CASSETTE (600mm)



VERSAL CASSETTE (750mm)



VERSAL CASSETTE (900mm)



VERSAL FREESTANDING

Linear Fire (conventional flue system)

DECORATION

Logs & chips

BACK WALL FINISH

Black matte steel (standard)
Black ceramic glass (optional)
Brick panel (optional)

CONTROL OPTIONS



STANDARD OPTIONAL COMPATIBLE



GASBOX

WOODBOX



Freestanding



Ambient LED illumination

VERSAL FREESTANDING

	400 mm 15 3/4"	600 mm 23 5/8"	750 mm 29 1/2"	900 mm 35 7/16"
	+ GASBOX 398 x 1213 x 320 mm 15 11/16" x 47 3/4" x 12 5/8" + WOODBOX 398 x 1013 x 320 mm 15 11/16" x 39 7/8" x 12 5/8"	+ GASBOX 598 x 1213 x 320 mm 23 5/8" x 47 3/4" x 12 5/8" + WOODBOX 598 x 1013 x 320 mm 23 5/8" x 39 7/8" x 12 5/8"	+ GASBOX 748 x 1213 x 320 mm 29 1/2" x 47 3/4" x 12 5/8" + WOODBOX 748 x 1013 x 320 mm 29 1/2" x 39 7/8" x 12 5/8"	+ GASBOX 898 x 1213 x 320 mm 35 7/16" x 47 3/4" x 12 5/8" + WOODBOX 898 x 1013 x 320 mm 35 7/16" x 39 7/8" x 12 5/8"
	(NG) max. 3.0 kW 10 236 BTU/h (LPG) max. 3.8 kW 12 966 BTU/h	(NG) max. 4.6 kW 15 696 BTU/h (LPG) max. 4.9 kW 16 719 BTU/h	(NG) max. 5.3 kW 18 084 BTU/h (LPG) max. 6.0 kW 20 473 BTU/h	(NG) max. 7.5 kW 25 591 BTU/h (LPG) max. 7.6 kW 25 932 BTU/h
	(NG) max. 0.32 m ³ /h 11.3 ft ³ /h (LPG) max. 0.30 kg/h 0.66 lbs/h	(NG) max. 0.49 m ³ /h 17.3 ft ³ /h (LPG) max. 0.39 kg/h 0.86 lbs/h	(NG) max. 0.56 m ³ /h 19.8 ft ³ /h (LPG) max. 0.47 kg/h 1.03 lbs/h	(NG) max. 0.79 m ³ /h 27.9 ft ³ /h (LPG) max. 0.60 kg/h 1.32 lbs/h
	Conventional			
	230 V / [US] 115 V			



VERSAL FREESTANDING (400MM)



VERSAL FREESTANDING (600mm)



VERSAL FREESTANDING (750mm)



VERSAL FREESTANDING (900mm)



PLANIKA DIRECT VENT

Traditional Collection (elevated burner)



BACK WALL FINISH

- Black matte steel
- Black ceramic glass
- Brick panel
- Corrugated steel

CONTROL OPTIONS

-  STANDARD
-  OPTIONAL
-  COMPATIBLE



Safe Glass System (mesh & glass screen)



Zero Clearance







Gas and CO detectors



Antireflective glass

PLANIKA DIRECT VENT

	(NG) 42 300 BTU/h (LPG) 40 950 BTU/h
	(NG) 46.3 ft ³ /h (LPG) 2.1 lbs/h
	Coaxial pipes 5" x 8"
	452.0 lbs
	[US] 115 V



BAY



CORNER



FRONT

GALIO CORTEN

Gas Technology

PROTECTIVE GLASS

DECORATION

Black diamond stones

CONTROL OPTIONS



STANDARD



OPTIONAL



COMPATIBLE



Custom shape



Smooth flame height regulation



Thermocouple

	GALIO CORTEN MANUAL (LPG)	GALIO CORTEN AUTOMATIC (NATURAL GAS/LPG)
	(LPG) max. 12.0 kW 40 946 BTU/h	(NG) max. 9.4 kW 32 074 BTU/h (LPG) max. 11.8 kW 40 263 BTU/h
	(LPG) max. 1.06 kg/h 2.33 lbs/h	(NG) max. 1.0 m ³ /h 35.3 ft ³ /h (LPG) max. 0.93 kg/h 2.05 lbs/h
	(LPG) 37 mbar 11"wc	(NG) 20 mbar 7"wc (LPG) 37 mbar 11"wc
	31.0 kg / 68.3 lbs	31.0 kg / 68.3 lbs



GALIO INSERT

Gas Technology

CONTROL OPTIONS



STANDARD



OPTIONAL



COMPATIBLE

DECORATION

Black diamond stones

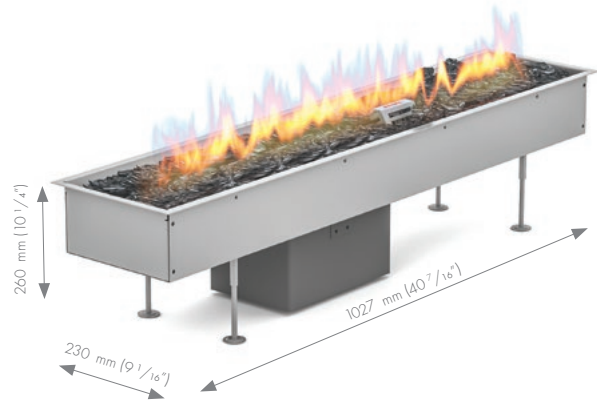
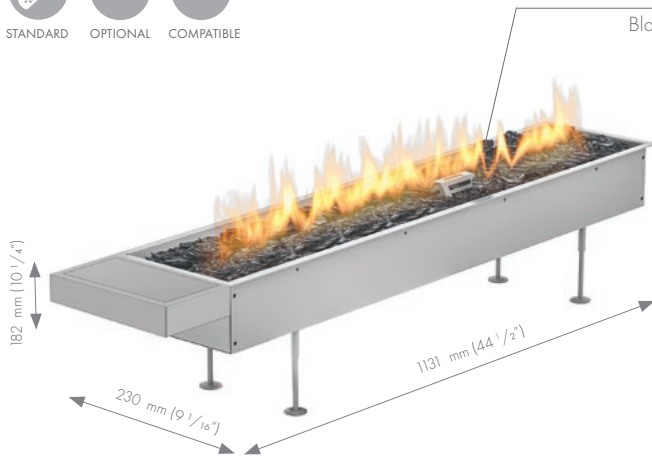

Custom shape



Smooth flame height regulation



Thermocouple



Easy to install

	GALIO INSERT MANUAL (LPG)	GALIO INSERT AUTOMATIC (NATURAL GAS/LPG)
	(LPG) max. 12.0 kW 40 946 BTU/h	(NG) max. 9.4 kW 32 074 BTU/h (LPG) max. 11.8 kW 40 263 BTU/h
	(LPG) max. 1.06 kg/h 2.33 lbs/h	(NG) max. 1.0 m ³ /h 35.3 ft ³ /h (LPG) max. 0.93 kg/h 2.05 lbs/h
	(LPG) 37 mbar 11"wc	(NG) 20 mbar 7"wc (LPG) 37 mbar 11"wc
	13.0 kg / 28.7 lbs	21.0 kg / 46.3 lbs



GALIO FIRE PIT

Gas Technology

CONTROL OPTIONS



STANDARD



OPTIONAL



COMPATIBLE



DECORATION
Black diamond stones



Custom shape



Smooth flame height regulation



Thermocouple



Easy to install

	GALIO FIRE PIT INSERT	GALIO FIRE PIT CORTEN
		(NG) max. 4.7 kW 16 037 BTU/h (LPG) max. 5.1 kW 13 990 BTU/h
		(NG) max. 0.5 m ³ /h 177 ft ³ /h (LPG) max. 0.98 kg/h 2.16 lbs/h
		(NG) 20 mbar 7"wc (LPG) 37 mbar 11"wc
	15.0 kg / 33.0 lbs	65.0 kg / 143.3 lbs



GUSTAV GAS

Gas Technology

CORTEN STEEL

DECORATION

Black diamond stones



GAS BOTTLE COMPARTMENT



Thermocouple



Anti-tilt shutoff valve



Freestanding

GUSTAV GAS



(LPG) max. 4.0 kW | max. 13650 BTU/h



(LPG) max. 0.32 kg/h | max. 0.7 lbs/h



(LPG) 37 mbar | 7"wc



32.0 kg / 70.5 lbs



LIGHTHOUSE

Gas Technology

TEMPERED GLASS



Tempered glass



Thermocouple



Anti-tilt shutoff valve



Freestanding

LIGHTHOUSE



(LPG) max. 4.0 kW | max. 13650 BTU/h



(LPG) max. 0.32 kg/h | max. 0.7 lbs/h



(LPG) 37 mbar | 7"wc



42.0 kg / 92.6 lbs